



**BOSS™**

Product Brochure

1300 134 651 | [dixonvalve.com.au](http://dixonvalve.com.au)

## Boss™ Coupling System

**Application**

- Boss™ couplings are all-purpose hose couplings, universally recommended for steam hose connections. They are also widely used for air, water, fluid petroleum chemicals, and liquid petroleum gas up to 25mm (1") ID. Boss™ couplings can be applied to many types of rubber, synthetic, plastic, metallic, or semi-metallic hose.

**Features**

- The Boss™ coupling system is made up of a spud, usually fixed to the equipment, and a stem, usually clamped to the hose. The two halves are connected or disconnected by rotating the wing nut on the spud. When connected, tightening the wing nut ensures a mechanical and pressure seal

**Seal Types**

- Ground Joint - copper or polymer seats
- Washer - Klingersil® C-4401

**F**

### Technical Information

Size		Air		Water		Steam	
mm	inch	PSI	Bar	PSI	Bar	PSI	Bar
6 to 50	¼ to 2	600	41	600	41	230	15.8
65 & 80	2½ & 3	450	31	450	31	230	15.8
100 & 150	4 & 6	250	17	250	17	230	15.8

### Materials

Coupling	Size		
	6mm - 25mm (¼" - 1")	32mm - 100mm (1¼" - 4")	150mm (6")
Stems	Plated Steel	Plated Malleable Iron	Tubular Steel
Spuds	Plated Steel	Plated Malleable Iron	Plated Malleable Iron
Wing Nuts	Plated Malleable Iron	Plated Malleable Iron	Plated Malleable Iron

### Female x Male Hose Assembly

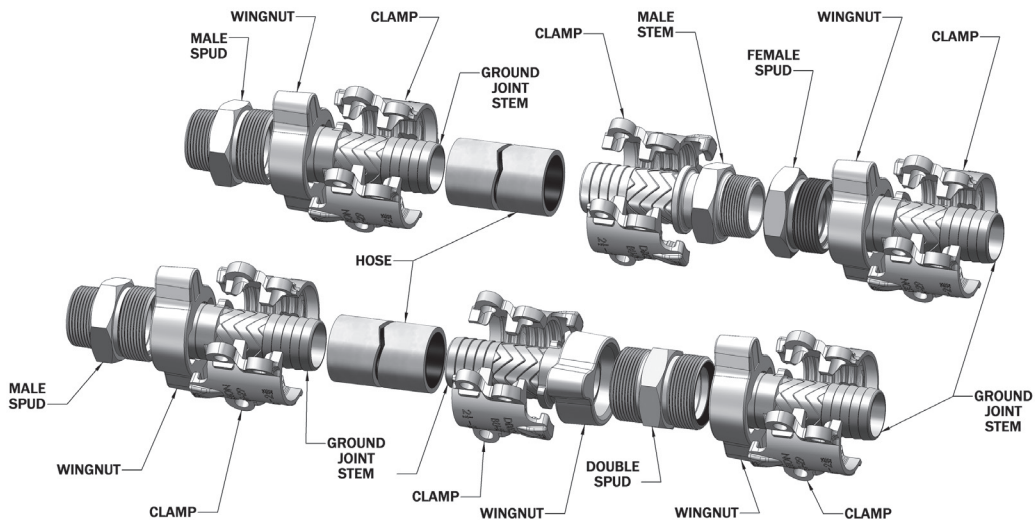

### Female x Female Hose Assembly



- Worn-out hose couplings can be dangerous. They should be checked regularly and replaced when necessary. Each coupling user should review applications and add safety devices where indicated

## Boss™ Complete Set

### Positive Metal-to-Polymer Seal

#### Features

- A leakproof seal is formed when the metal head of the stem makes contact with the patented polymer seat in the spud
- The non-metallic polymer seat resists most chemicals found in manufacturing facilities
- Recommended for steam service up to 230°C (450°F)
- Easy to seal
- Plated steel BSP, plated steel and/or malleable iron NPT, stainless steel NPT or Brass NPT
- Use with Dixon™ Boss™ clamps, refer to page 9

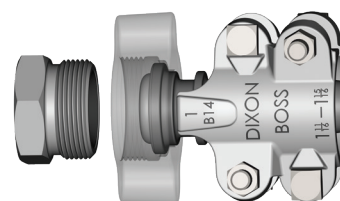

Size		Part Numbers			
mm	inch	Plated Steel (BSP)	Plated Steel or Iron (NPT)	Stainless Steel (NPT)	Brass (NPT)
6	¼	GF1A	GF1 <sup>1</sup>	-	-
9.5	⅜	FG3A	GF3 <sup>1</sup>	-	-
12	½	GF6A	GF6	-	-
20	¾	GF26A	GF26	RGF26	BGF26
25	1	GF36A	GF36	RGF36	BGF36
32	1¼	GF51A	GF51	RGF51	BGF51
48	1½	GF61A	GF61	RGF61	BGF61
50	2	GF81A	GF81 <sup>2</sup>	RGF81 <sup>2</sup>	BGF81
65	2½	GF96A	GF96	-	-
80	3	GF111A	GF111	-	-
100	4	GF141A	GF141	-	-



Stainless Steel



Plated Steel/Iron

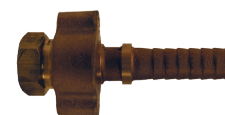

Brass

<sup>1</sup> ¼" & ⅜" available only with copper seat spuds

<sup>2</sup> Not to be used with #250, #275 or #306 Boss™ clamps

Product Group: AD01

## Boss™ Ground Joint Seal Fittings

### Boss™ Stems

Size		Part Numbers		
mm	inch	Plated Steel or Iron	Stainless Steel	Brass
6	¼	GBA <sup>1</sup>	-	-
9.5	⅜	GCA <sup>1</sup>	-	-
12	½	GB1	-	-
20	¾	GB6	RGB26	BGB26
25	1	GB11	RGB36	BGB36
32	1¼	GB16	RGB51	BGB51
40	1½	GB21	RGB61	BGB61
50	2	GB26 <sup>2</sup>	RGB81 <sup>2</sup>	BGB81
65	2½	GB31	-	-
80	3	GB36	-	-
100	4	GB46	-	-
150	6	GB66	-	-



Plated Steel/Iron



Stainless Steel



Brass

<sup>1</sup> ¼" & ⅜" available only with copper seat spuds

<sup>2</sup> Not to be used with #250, #275 or #306 Boss™ clamps

Product Group: AD01



**Boss™ Female Spud**

Size		Part Numbers			
mm	inch	Plated Steel BSP x Wing Nut	Plated Steel NPT x Wing Nut	316SS NPT x Wing Nut	Brass NPT x Wing Nut
6	¼	GBC <sup>1</sup>	-	-	-
9.5	⅜	GCC <sup>1</sup>	GCCA	-	-
12	½	GB3	GB3A	-	-
20	¾	GB8	GB8A	RGB8	BGB8
25	1	GB13	GB13A	RGB13	BGB13
32	1¼	GB18	GB18A	RGB18	-
40	1½	GB23	GB23A	RGB23	-
50	2	GB28	GB28A	RGB28	-
65	2½	GB33	GB33A	-	-
80	3	GB38	GB36A	-	-
100	4	GB48	GB48A	-	-
150	6	GB68	GB68A	-	-

<sup>1</sup> ¼", ⅜" & 6" available only with copper seat spuds, all other sizes have polymer seats

Product Group: AD01

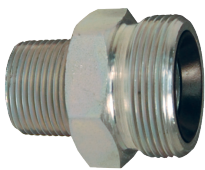

**Boss™ Male Spud**

Size		Part Numbers			
mm	inch	Plated Steel BSP x Wing Nut	Plated Steel NPT x Wing Nut	Plated Iron	Plated Steel/Iron NPT x Wing Nut
6	¼	GMBA <sup>1</sup>	-	-	GMB <sup>1</sup>
9.5	⅜	GMCA	GMC <sup>1</sup>	-	-
12	½	GM3A	GM3	-	-
20	¾	GM8A	GM8	-	-
25	1	GM13A	GM13	-	-
32	1¼	GM18A	-	GM18	-
40	1½	GM23A	-	GM23	-
50	2	GM28A	-	GM28	-
65	2½	GM33A	-	GM33	-
80	3	GM38A	-	GM38	-

<sup>1</sup> ¼", ⅜" & 6" available only with copper seat spuds, all other sizes have polymer seats

Product Group: AD01

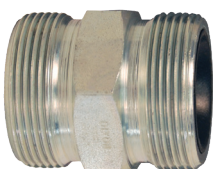

**Boss™ Double Spud**

Size		Part Numbers	
mm	inch	Plated Steel - Wing Nut	Plated Iron - Wing Nut
12	½	GDB3	-
20	¾	GDB13	-
25	1		
32	1¼	-	GDB23
40	1½	-	GDB26
50	2	-	GDB33
65	2½	-	GDB38
80	3	-	GDB38

Product Group: AD01

## Boss™ Washer Seal Complete Set

### Washer Seal Type

#### Features

- Easy to seal
- Klingersil® C-4401 washer is inserted between the stem and spud
- Leakproof seal forms by rotating the wing nut and hammering it tight
- Use with Boss™ clamps, refer to page 9

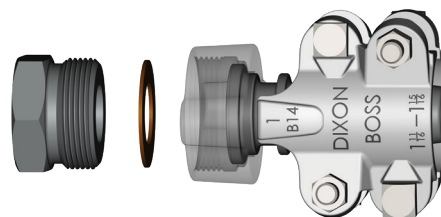

Size		Part Numbers			
		Complete Set	Complete Set Components		
mm	inch		Stem	Female Spud	Wing Nut
9.5	3/8	WF3	CA	CC	CB
12	1/2	WF6	B1	B3	B2
20	3/4	WF26	B6	B13	B12
25	1	WF36	B11	B13	B12
32	1 1/4	WF51	B16	B18	B17
40	1 1/2	WF61	B21	B18	B17
50	2	WF81 <sup>1</sup>	B26 <sup>1</sup>	B28	B17
65	2 1/2	WF96	B31	B33	B32
80	3	WF111	B36	B38	B37

<sup>1</sup>Not to be used with #250, #275, or #306 Boss™ clamps

Product Group: AD01

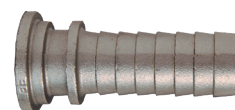

Stem



Spud



Wingnut

## Boss™ Washer Seal Fittings

### Boss™ Wing Nut

Size		Part Numbers		
		Plated Steel/Iron	Stainless Steel	Brass
6	1/4	BA2 <sup>2</sup>	-	-
12	1/2	B2	-	-
20	3/4	B12	W12	BB12
25	1			
32	1 1/4	B17	W17	BB17
40	1 1/2			
50	2	B27	W27	BB27
65	2 1/2	B32	-	-
80	3	B37	-	-
100	4	B47	-	-
150	6	B67	-	-

<sup>2</sup> BA2 not for use with the Boss™ washer seal

Product Group: AD01



Plated Steel



Stainless Steel



Brass

**Boss™ Washer Seal Washer**

**Material**

- Nitrile rubber bonded, non-asbestos Klingersil® C-4401



Size		Part Numbers
mm	inch	
20	¾	W12
25	1	
32	1¼	W17
40	1½	
50	2	W27
65	2½	W32
80	3	W37

Product Group: AD01

**Boss™ Washer Seal Double Spud**

**Material**

- Plated iron

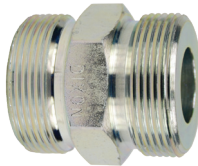

Size		Part Numbers
mm	inch	
20	¾	DB13
25	1	
32	1¼	DB23
40	1½	
50	2	DB28
80	3	DB38

Product Group: AD01

**Boss™ Ground Joint Adaptors**



Male Adaptor



Female Adaptor



Cap

Size		Part Numbers		
mm	inch	Male NPT Adaptor Plated Steel/Iron	Female NPT Adaptor Plated Steel/Iron	Boss™ Wing Nut Cap Plated Iron
20	¾	GMAS6	GFAS6 <sup>2</sup>	B12SC4
25	1	GMAS11	GFAS11 <sup>3</sup>	
32	1¼	-	-	B17SC4
40	1½	GMAS21	-	
50	2	GMAS26 <sup>1</sup>	GFAS26 <sup>1</sup>	B27SC4
80	3	GMAS36	-	B37SC4
100	4	GMAS46	-	-

<sup>1</sup>GMAS26 & GFAS26 takes a special wing nut - part number B27-1

<sup>2</sup>Couplings come with adaptor and wing nuts

<sup>3</sup>Wing nut is permanently attached on the 25mm (1")

Supplied with 300mm (12") chain & washer

Boss™ wing nut caps are not intended for pressure applications

Product Group: AD01

## Boss™ Holedall™ Fittings

### Application

- Designed for air and liquid applications where a permanent, low profile clamping system is desired.
- Not to be used for steam.

### Features

- Supplied with carbon steel ferrules

Size		Part Numbers		Hose OD (mm)	
mm	inch	Plated Steel or Iron	Stainless Steel	from	to
20	¾	GF26P1	-	29.36	30.95
		GF26P2	-	31.35	32.54
		GF26P3	-	32.94	34.13
25	1	GF36P2	-	37.30	38.89
		GF36P2	-	39.29	39.68
		GF36P3	-	40.87	42.06
40	1½	GF61P1	RGF61P1	33.33	50.80
		GF61P2	RGF61P2	51.19	53.97
		GF61P3	-	54.37	57.15
50	2	GF81P1	RGF81P1	65.08	66.67
		GF81P2	RGF81P2	67.07	69.85
		GF81P3	-	70.24	73.02
80	3	GF111P1 <sup>1</sup>	-	86.51	92.07
		GF111P2 <sup>1</sup>	-	92.29	95.25
		GF111P3 <sup>1</sup>	-	95.64	98.42

<sup>1</sup> 80mm (3") have a machined shank

Product Group: AD01

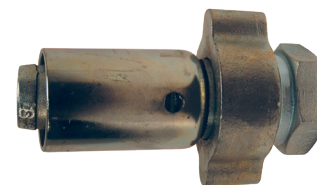

F

## Boss™ Male Stems

### Steel Bar Stock

Size (Hose x Thread)		Part Numbers	
mm	inch	BSP	NPT
6 x 3	¼ x ⅛	-	MS4X2
6 x 6	¼ x ¼	-	MSA
6 x 10	¼ x ⅜	-	MS8
10 x 6	⅜ x ¼	MS6X4A	MS6X4
10 x 10	⅜ x ⅜	MSCA	MSC
10 x 15	⅜ x ½	MS6X8A	MS6X8
15 x 6	½ x ¼	MS8X4A	MS8X4
15 x 10	½ x ⅜	MS8X6A	MS8X6
15 x 15	½ x ½	MS1A	MS1
15 x 20	½ x ¾	MS8X12A	MS8X12
20 x 15	¾ x ½	MS12X8A	MS12X8
20 x 20	¾ x ¾	MS6A	MS6
20 x 25	¾ x 1`	MS12X16A	MS12X16
25 x 20	1 x ¾	MS16X12A	MS16X12
25 x 25	1 x 1	MS11A	MS11

Product Group: AD01





**Plated Iron**

Size		Part Numbers	
mm	inch	BSP	NPT
32	1¼	MS16A	MS16
40	1½	MS21A	MS21
50	2	MS26A	MS26
65	2½	-	MS31
75	3	MS36A	MS36
100	4	MS46A	MS46

Use with Boss™ clamps, refer to page 10

Product Group: AD01

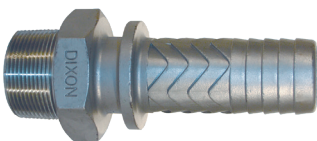

**316 Stainless Steel**

Size		Part Numbers	
mm	inch	BSP	NPT
15	½	RMS1A	RMS1
20	¾	RMS6A	RMS6
25	1	RMS11A	RMS11
32	1¼	RMS16A	RMS16
40	1½	RMS21A	RMS21
50	2	RMS26A	RMS26
65	2½	-	RMS31
75	3	-	RMS36

Use with Boss™ clamps, refer to page 9

Product Group: AD01

**Boss™ Hose Menders**



Size		Part Numbers	
mm	inch	Plated Malleable Iron	Plated Steel
15	½	-	M1
20	¾	M6	-
25	1	M11	-
32	1¼	M16	-
40	1½	M21	-
50	2	M26	-
65	2½	M31	-
75	3	M36	-

Use with Boss™ clamps, refer to page 9

Product Group: AD01



## Boss™ 2-Bolt Type Clamp

### Features

- Recommended for steam service up to 230°C
- 2 gripping fingers

### Use

- Bolts in Boss™ clamps are designed to bend as they are tightened
- Periodic retightening of bolts is required due to "cold flow" present in all rubber hoses
- Boss™ clamps are for single use only

### Installation

- Secure the assembly in a vice
- Using a torque wrench, tighten bolts as follows:
  1. First bolt (nut facing assembler) 1-full turn
  2. Second bolt (opposite first bolt) 1-full turn
  3. Repeat process 1 & 2 until both bolts have reached the recommended torque
  4. Remove assembly from vice

### Investment Cast Carbon Steel

Hose ID		Hose OD (mm)		Part Numbers	Bolt Torque	
mm	inch	from	to		ft-lbs	Nm
6	¼	14.3	16.7	BD	6	8.1
10	⅜	17.4	22.2	CC	6	8.1
12.7	½	20.6	23.8	DD	6	8.1
12.7	½	23.8	27.0	B4	12	16.3
20	¾	30.2	33.3	BU9	21	28.5
20	¾	38.1	42.9	B10	21	28.5

Product Group: AD04



### Zinc Plated Iron

Hose ID		Hose OD (mm)		Part Numbers	Bolt Torque	
mm	inch	from	to		ft-lbs	Nm
12.7	½	27.0	30.2	B5	12	16.3
20	¾	33.3	38.1	B9	21	28.5

Product Group: AD04



### Stainless Steel

Hose ID		Hose OD (mm)		Part Numbers	Bolt Torque	
mm	inch	from	to		ft-lbs	Nm
12.7	½	23.8	27.0	RB4	12	16.3
20	¾	30.2	33.3	RB9	21	28.5
20	¾	33.3	38.1	RB9	21	28.5

Product Group: AD04



### Brass

Hose ID		Hose OD (mm)		Part Numbers	Bolt Torque	
mm	inch	from	to		ft-lbs	Nm
12.7	½	23.8	27.0	BB4	12	16.3
20	¾	30.2	33.3	BB9	21	28.5

Product Group: AD04



- The bolts used in the Boss™ interlocking clamps are not standard. They vary from standard bolts in their length, diameter, overall thread length, and material hardness. These bolts can be retorqued, but it is not recommended that the bolts or clamps be reused, as they are designed for a single bend only
- Torque values for clamps are based on dry bolts. The use of lubricant on bolts will adversely affect clamp performance. Do not lubricate nuts and bolts
- Worn-out couplings can be dangerous. They should be checked regularly and replaced

## Boss™ 4-Bolt Type Clamp

**Features**

- Recommended for steam service up to 230°C
- 2 or 4 gripping fingers

**Use**

- Bolts in Boss™ clamps are designed to bend as they are tightened
- Periodic retightening of bolts is required due to "cold flow" present in all rubber hoses
- Boss™ clamps are for single use only

**Installation**

- Secure the assembly in a vice
- Using a torque wrench, tighten bolts as follows;
  1. Back bolt (nut facing assembler that is furthest away from gripping finger) 1-full turn
  2. Front bolt (nut facing assembler that is closest to gripping finger) 1-full turn
  3. Move to nuts on opposite side of bolts just torqued (if bolts are loose) snug bolts by hand
  4. Opposite side back bolt (nut facing assembler furthest away from gripping finger) 1-full turn
  5. Move to nuts on opposite side of bolts just torqued (if bolts are loose) snug bolts by hand
  6. Repeat above process 1 - 7 until all bolts have reached the recommended torque - as per below table
  7. Remove assembly from vice

**F**



### 2 Gripping Fingers - Zinc Plated Iron

Hose ID		Hose OD (mm)		Part Numbers	Bolt Torque	
mm	inch	to	from		ft-lbs	Nm
25	1	38.9	43.7	BU14	21	28.5
25	1	42.9	49.2	B14	21	28.5
25	1	49.2	54.0	B15	21	28.5
32	1¼	38.1	45.2	BU18	40	54.2
32	1¼	45.2	53.2	BU19	40	54.2
32	1¼	54.0	60.3	B19	40	54.2
40	1½	56.0	50.8	BU22	40	54.2
40	1½	50.8	56.4	B22	40	54.2
40	1½	55.6	60.3	BU24	40	54.2
40	1½	60.3	65.1	B24	40	54.2
40	1½	65.1	69.9	B25	40	54.2
50	2	59.5	64.3	BU28	60	81.3
50	2	63.5	70.6	BU29	60	81.3
50	2	69.9	77.8	B29	60	81.3
50	2	78.6	87.3	B30	60	81.3
65	2½	78.6	87.3	BU34	60	81.3
65	2½	88.9	100.0	B34	150	203.4
75	3	88.9	100.0	BU35	150	203.4
75	3	96.8	103.2	B35	150	203.4
75	3	103.2	112.7	B39	200	271.2

Product Group: AD04



### 2 Gripping Fingers - Stainless Steel

Hose ID		Hose OD (mm)		Part Numbers	Bolt Torque	
mm	inch	to	from		ft-lbs	Nm
25	1	38.9	43.7	RBU14	21	28.5
40	1½	55.6	60.3	RBU24	40	54.2
40	1½	60.3	65.1	RB24	40	54.2
50	2	63.5	70.6	RBU29	60	81.3
50	2	69.9	77.8	RB29	60	81.3
75	3	88.9	100.0	RBU35	150	203.4

Product Group: AD04

## 2 Gripping Fingers - Brass

Hose ID		Hose OD (mm)		Part Numbers	Bolt Torque	
mm	inch	to	from		ft-lbs	Nm
25	1	38.9	43.7	BBU14	18	24.4
25	1	42.9	49.2	BB14	28	38.0

Product Group: AD04



## 4 Gripping Fingers - Zinc Plated Iron

Hose ID		Hose OD (mm)		Part Numbers	Bolt Torque	
mm	inch	to	from		ft-lbs	Nm
12.7	½	23.0	26.2	968	6	8.1
25	1	35.7	39.7	156	21	28.5
32	1¼	42.9	47.6	187	21	28.5
32	1¼	47.6	52.4	206	21	28.5
40	1½	50.8	54.0	212	21	28.5
40	1½	52.4	57.2	225	40	54.2
50	2	57.2	63.5	250	40	54.2
50	2	63.5	69.9	275	40	54.2
50	2	69.9	77.8	306	60	81.3
65	2½	77.8	88.9	350	60	81.3
75	3	88.9	95.3	375	60	81.3
75	3	95.3	101.6	401	150	203.4
75	3	101.6	106.4	418	200	271.2
75	3	106.4	114.3	450	200	271.2

Product Group: AD04



## Boss™ 6-Bolt Type Clamp

## Features

- Recommended for steam service up to 230°C
- 3 gripping fingers

## Use

- Bolts in Boss™ clamps are designed to bend as they are tightened
- Periodic retightening of bolts is required due to "cold flow" present in all rubber hoses
- Boss™ clamps are for single use only

## Installation

- Secure the assembly in a vice
- Using a torque wrench, tighten bolts as follows;
  1. Back bolt (nut facing assembler that is furthest away from gripping finger) 1-full turn
  2. Front bolt (nut facing assembler that is closest to gripping finger) 1-full turn
  3. Move to clamp segment to the left of the one just torqued (if bolts are loose) snug bolts by hand
  4. Back bolt 1-full turn
  5. Front bolt 1-full turn
  6. Move to clamp segment to the left of the one just torqued (if bolts are loose) snug bolts by hand
  7. Back bolt 1-full turn
  8. Front bolt 1-full turn
  9. Repeat above process 1 - 8 until all bolts have reached the recommended torque
  10. Remove assembly from vice

Hose ID		Hose OD (mm)		Part Numbers	Bolt Torque	
mm	inch	to	from		ft-lbs	Nm
75	3	108.0	122.2	BS39	150	204
100	4	117.5	127.0	B45	150	204
100	4	123.8	133.4	BS49	200	272
100	4	133.4	142.1	BU49	200	272
100	4	140.5	150.8	B49	200	272
150	6	174.6	187.3	750	200	272
150	6	190.5	203.2	850	200	272

Product Group: AD04



